

## Please Read Before Operating!

Your scooter is packaged with a packet of tools you will need for initial setup.  
Please locate this packet first.

- 1.** Remove your scooter from its packaging. Raise the tiller by loosening the tiller knob, lifting the tiller into place, then retightening the knob.

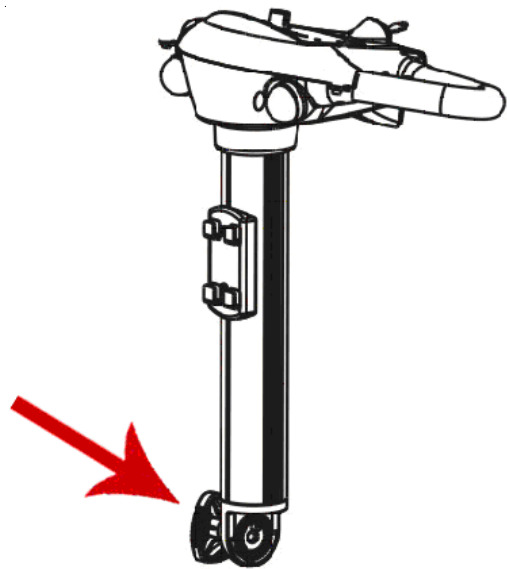

- 2.** Remove the two knobs on the rear cover and lift up carefully on the rear cover to remove. The rear cover will still be connected to the scooter by the white taillight connector cable.

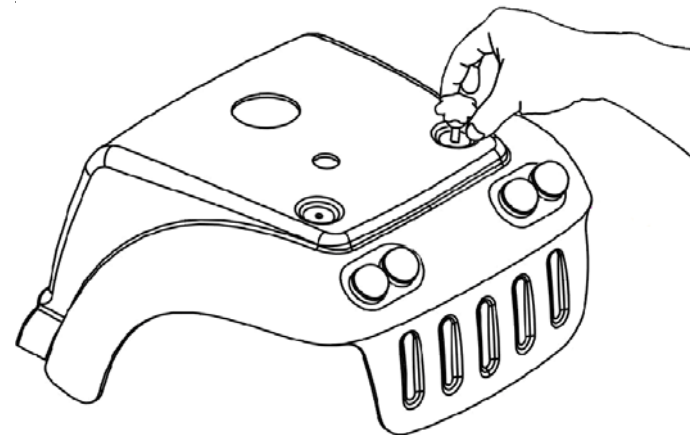

- 3.** Install the seat post. Ensure that the seat post is aligned so that the two flanges with holes are facing the rear of the product. Having these flanges rotated into any other position will result in instability in the seat.

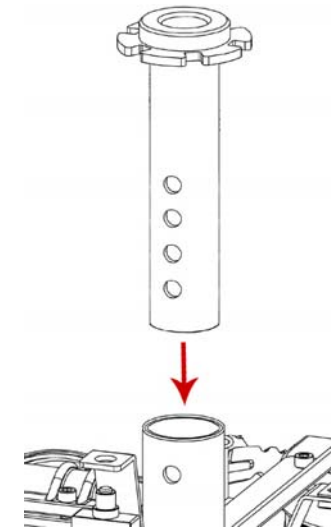

- 4.** From behind the product, looking forward, insert the seat bolt into hole on the left side of the seat post. This bolt is also used to adjust the seat height. Insert the bolt as far into the hole as it will go, making sure that the bolt passes all the way through to the hole on the opposite side. Install the washer and nut and tighten them using the included flat wrench.

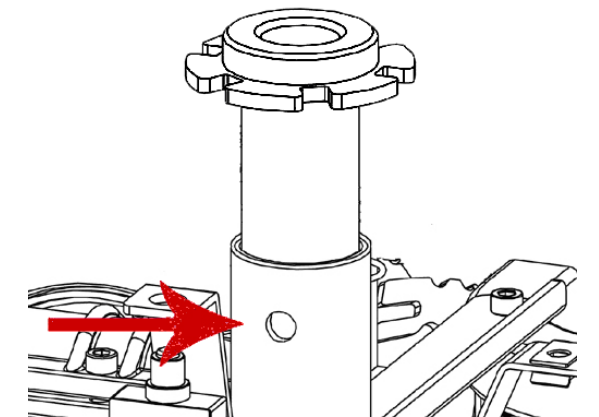

- 5.** Attach the two battery connectors to the batteries (red to red and black to black).

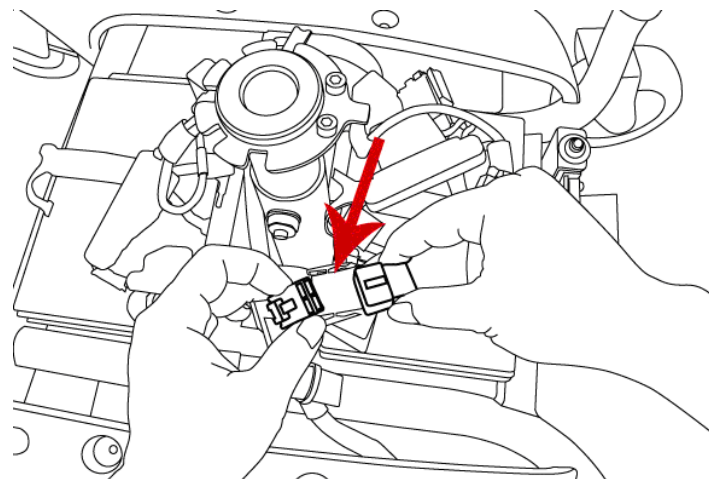

- 6.** Replace the rear cover, making sure the tabs on the bottom of the rear cover fit into the slots in the scooter's floorboard. Replace and tighten the two knobs removed in Step 2.

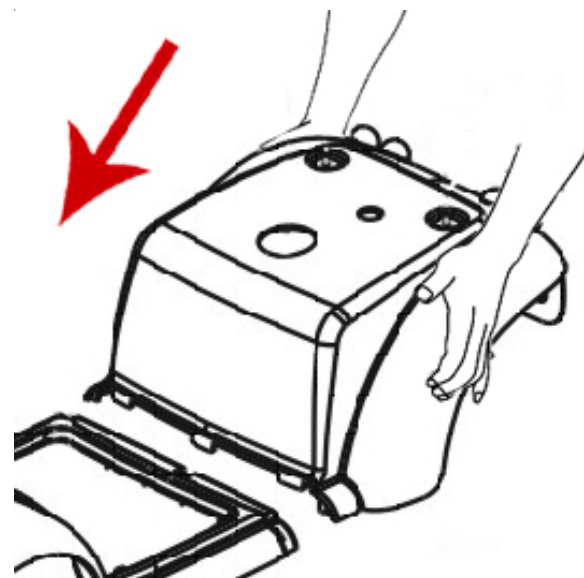

- 7.** Lift the seat and pull the swivel lever up at the same time. Lower the bottom of the seat onto the seat post. Release the lever, swivel the seat and push down on the seat until it locks in place.

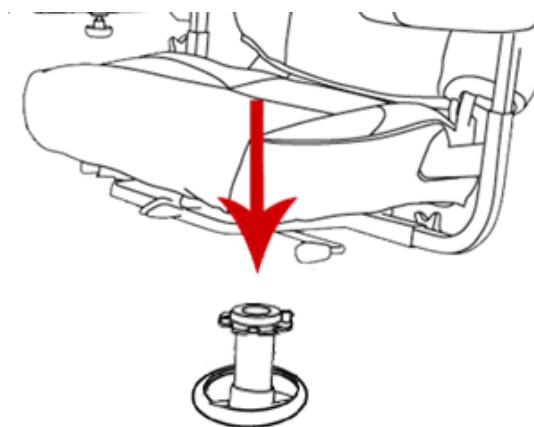

 **NOTE:** Get help when placing the seat onto the post to avoid scratching the cover shroud.

- 8.** Insert the armrests into the attachment points in the seat frame so that the armrests face forward.

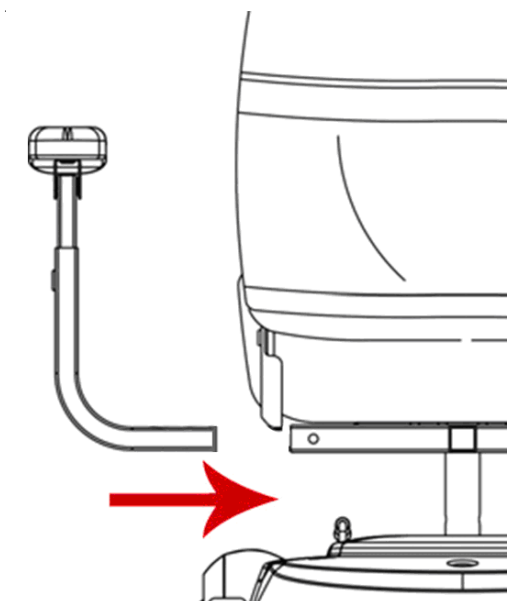

- 9.** Insert and tighten the included star knobs to lock the armrests into place at the desired width.

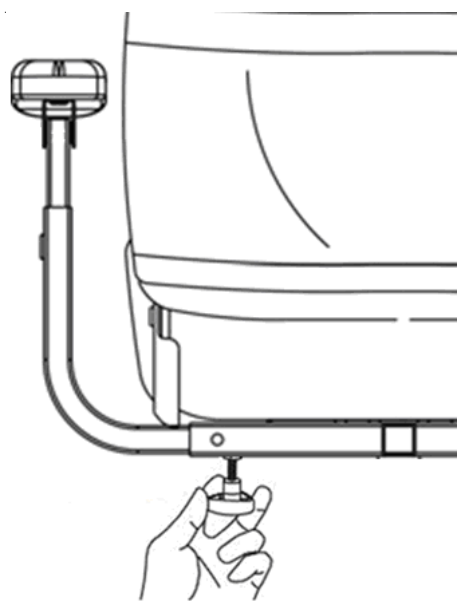

- 10.** Affix the headrest to the top of the seat by inserting the headrest posts into the holes in the top of the seat.

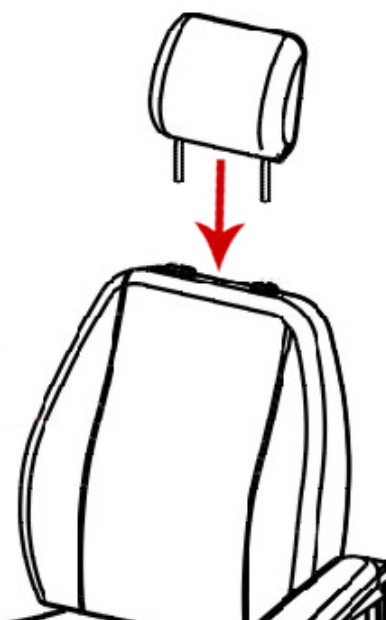

- 11.** Use the flat wrench included in the tool kit to affix the rearview mirrors to the product's control panel.

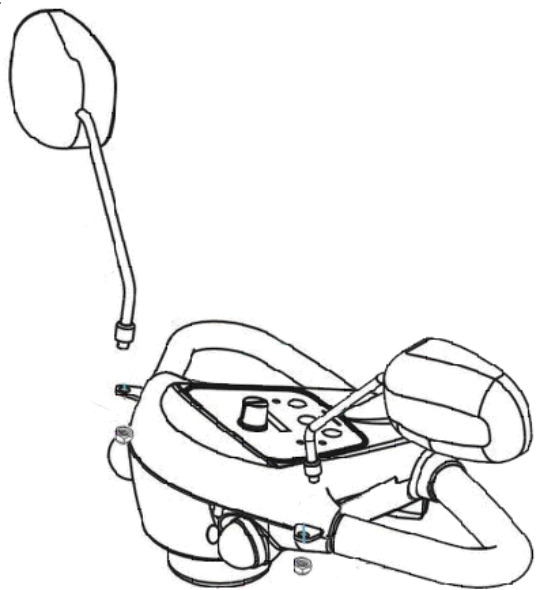

- 12.** Affix the front basket to the bracket on the front of the scooter's tiller

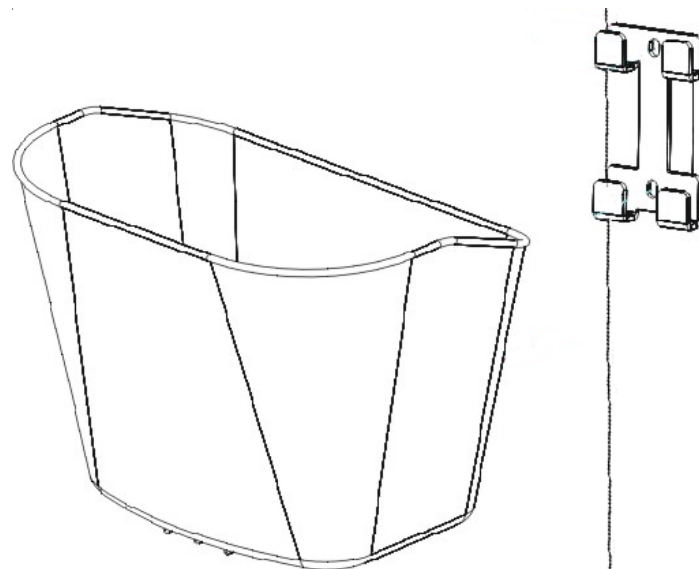

- 13.** Fully charge the scooter's batteries by inserting the round charger connector into the battery charging terminal on the scooter's control panel and inserting the 3-pronged plug into a standard electrical outlet.

Ensure that the 115V/230V switch on the product's battery charger is set to 115V. If the switch is set to 230V, the scooter will not charge properly. Full charging normally takes 6-8 hours, but can take as many as 10 hours depending on the batteries' charge level when starting and the ambient temperature.

## Pilot Quick Start Guide



### READ BEFORE UNPACKING

This Quick Start Guide offers basic information on initial product setup only. Read the owner's manual and all supplemental information thoroughly before operating the product for information on safety, battery charging, basic operation, comfort adjustments, disassembly and care and maintenance.

**NOTE:** The illustrations provided may not reflect your actual unit.

#### Apparent Loss or Damage

Should visual inspection upon receipt of this shipment show loss or damage, it must be noted on the freight bill or express receipt and signed by the carrier's agent. Failure to do this may result in the carrier refusing to honor claim.

The carrier will forward you the necessary form(s) for filing claim.

#### Concealed Loss or Damage

When loss or damage is not apparent until the unit is unpacked, then a claim for concealed damage is entered by the receiver. When damage is discovered, make a written request to the carrier for inspection.

Keep all cartons and fillers. You must make this request for inspection within twenty-four (24) hours of the delivery. The carrier will furnish you with an inspection report and the necessary form(s) for filing concealed damage or loss claim. It is the receiver's responsibility to file such claims for concealed damage.